



**AGENDA FOR
REGULAR CITY COUNCIL MEETING
TUESDAY, MAY 16, 2023 – 5:00 P.M.**

1. **Pledge of Allegiance**
2. **Call to Order**
 - Roll Call and Establishment of Quorum
3. **Approval of Agenda**
 - Council Changes
 - Staff Changes
4. **Approval of Minutes**
 - A. May 2, 2023
5. **Audience Participation** (10-minute time limit for items not on the agenda)
6. **Consent Agenda**
 - A. Approve Asphalt Roller Purchase
 - B. Approve Electric Department Crew Cab Pickup Purchase
 - C. Approve Street Department Pickup Purchase
 - D. Approve Water Department Double Cab Pickup/Utility Box Purchase
7. **Scheduled Public Hearings**
8. **Old Business**
9. **Regular Agenda**
 - A. Donation from Redwood Area Junior Olympics Volleyball Association – Resolution #27
 - B. Nuvera Fiber Expansion Project Update
 - C. Fourth Street Reconstruction Project – Approval of Plans and Authorization to Bid
 - D. Conflict Prosecution Services Agreement – Resolution #28
 - E. Establish City Council Work Session Agenda
10. **Other Items and Communications**
 - A. Council Items
 - B. Staff Items
11. **Paid Bills and Claims – For Informational Purposes**
 - A. City of Redwood Falls Accounts Payable Summary
12. **Adjournment**

**MINUTES
REGULAR COUNCIL MEETING
CITY OF REDWOOD FALLS, MINNESOTA
TUESDAY, MAY 2, 2023**

Pursuant to due call and notice thereof, a regular meeting of the Redwood Falls City Council was called to order in the Municipal Chambers on Tuesday, May 2, 2023, at 5:00 p.m.

Roll call indicated Mayor Tom Quackenbush and Council Members Matt Smith, Denise Kerkhoff, Larry Arentson, and John T. Buckley were present, constituting a quorum. Council Member Jim Sandgren was absent.

Also present were City Administrator Keith Muetzel, Finance Director Kari Klages, City Attorney Trenton Dammann, Public Works Project Coordinator Jim Doering, and Deputy City Clerk Caitlin Kodet.

A motion was made by Council Member Buckley and seconded by Council Member Arentson to approve the agenda. Motion passed by unanimous vote.

A motion was made by Council Member Smith and seconded by Council Member Buckley to approve the April 18, 2023, minutes as presented. Motion passed by unanimous vote.

A motion was made by Council Member Buckley and seconded by Council Member Arentson to approve the April 18, 2023, Board of Equalization and Review minutes as presented. Motion passed by unanimous vote.

A motion was made by Council Member Kerkhoff and seconded by Council Member Smith to approve the following items on the Consent Agenda:

1. Administrative Hearing Officer Appointment
2. Parade Permit Application – MMIR Prayer and Honor Walk
3. Thriveon 2023 Quarter Two PC Refresh
4. Community Center Floor Scrubber Replacement
5. Tobacco License – The Market at Redwood

Motion passed by unanimous vote.

City Attorney Dammann introduced the Plat Corrections for Reflection Ridge and Reflection Prairie.

Mr. Dammann stated on April 19, 2022, Council approved the preliminary plats and final plats for the parcels described as the Reflection Prairie Addition (Parcel #62-008-2020) and Reflection Ridge Business Park Addition (Parcel #62-005-4020). The approved final plats were filed with the office of the Redwood County Recorder on July 7, 2022. Pursuant to Minn. Stat. § 505.174, when a land plat has been executed and filed in the office of the county recorder of the county where the land is situated, and the plat fails to correctly describe the land to be platted, the registered surveyor who prepared such plat or subdivision may execute a certificate stating the nature of the error, omission or defect and stating the correct information to correct such error. Bolton & Menk Inc., has identified errors in the listed acreage of certain tracts of land in both final plats and have prepared Land Surveyors Certificates to correct those errors, listing the correct amount of acreage for each lot and/or block. Once approved, these certificates will be filed with the Redwood County Recorder's Office.

A motion was made by Council Member Smith and seconded by Council Member Arentson to approve the Plat Corrections for Reflection Ridge and Reflection Prairie. Motion passed by unanimous vote.

City Administrator Muetzel introduced the Public Utilities Superintendent Position.

Mr. Muetzel stated the current Public Utilities Superintendent, Chuck Heins, has announced a retirement date of August 31, 2023, and the hiring committee has completed the selection process for the next Superintendent. The position was posted internally, and an application was received from Jason Halvorson. Jason has worked for the City of Redwood Falls for 11 years and currently serves as the Electric Line Foreman.

Mr. Muetzel stated City Administration is supportive of transitioning Jason into the Public Utilities Superintendent position. This transition will occur over the next several months and become official on September 4. During this time, some of the position's administrative responsibilities will be adjusted and may be moved to other administration/finance staff.

A motion was made by Council Member Kerkhoff and seconded by Council Member Smith to approve the Public Utilities Superintendent Position offer to Jason Halvorson. Motion passed by unanimous vote.

Council Member Smith requested information regarding the development proposals received for the Reflection Prairie Addition. City Administrator Muetzel stated additional information is being gathered from both parties and it would possibly be another 30 days before Council can finalize the proposals. Construction could begin tentatively in the spring of 2024.

Mayor Quackenbush stated the City Council Work Session will be on Tuesday, May 30, 2023. Council and Staff should prepare possible agenda topics.

Council Member Buckley requested an update regarding the fishing pier for Lake Redwood. Public Works Project Coordinator Doering stated parts of the pier are currently back ordered and will hopefully be installed later this summer.

Mayor Quackenbush requested an update on the former hospital redevelopment, Red Skye Lofts. City Administrator Muetzel stated construction is progressing. Red Skye Lofts is currently accepting potential residents on a waitlist. The expected completion date is the fall of 2023.

Bills and Claims were presented to the Council for informational purposes. No questions, comments or concerns were raised.

There being no further business, a motion was made by Council Member Buckley and seconded by Council Member Arentson to adjourn the meeting at 5:27 p.m. Motion passed by unanimous vote.

ATTEST:

Keith Muetzel
City Administrator

Tom Quackenbush
Mayor

Meeting Date: May 16, 2023

AGENDA RECOMMENDATION

Agenda Item: 1996 Steel Drum Roller Trade with RMS Equipment.

Recommendation/Action Requested: Staff recommends approval of proposal from RMS Equipment.

Summary/Overview: The 2023 Central Garage Operating Budget includes \$60,000.00 to replace the existing roller. Staff requests approval to purchase the roller from RMS Co. for \$43,125.00.

Attachments: RMS Co. Proposal – \$43,125.00
RDO Equipment Proposal – \$50,362.40



Road Machinery & Supplies Co.

We supply the equipment, support, and technology solutions that enable our customers to build infrastructure and industry in the communities we serve.

Quote #: mb2-0367
4/25/2023 11:59 AM
Page 1 of 4
507-508-9370
mbuchanan@rmseq.com

Billing Address:
CITY OF REDWOOD FALLS PUBLIC UTILITIES
REDWO001
PO BOX 526
REDWOOD FALLS MN 56283
Main Phone# 5076375755
Contact: Darrell Bowers
Email: dbowers@ci.redwood-falls.mn.us

Shipping Address:
01 - SAVAGE Store
5633 HWY 13 WEST
SAVAGE MN 55378

2021 BOMAG MODEL BW120SL-5 ROLLER S/N 961880701229, STOCK # 056639 W/ 2 HOURS

\$47,500.00

Equipped as follows:

- S19 ROPS, hinged
- FS33 Sliding seat plus extras
- VM25 Economizer+ °C/°F -display
- E26 Battery disconnect switch
- E16 Rotary beacon

Manufacturer	Model	Serial #	TRADE-INS		Year	Hours
			Trade \$			
Ingersall Rand	DD-24	146151	\$4,375.00		1996	2039

Sub Total:	\$47,500.00
Less Trade:	(\$4,375.00)
Total Selling Price:	\$43,125.00
RMS SAVAGE	

On behalf of Road Machinery & Supplies Co., thank you for the opportunity to quote this equipment!

Sincerely,

Mike Buchanan
Territory Manager

** Subject to all applicable taxes. This proposal is good for 30 days and subject to availability. Pricing is subject to change without notice.*



Road Machinery & Supplies Co.

We supply the equipment, support, and technology solutions that enable our customers to build infrastructure and industry in the communities we serve.

Quote #: mb2-0367
4/25/2023 11:59 AM
Page 3 of 4
507-508-9370
mbuchanan@rmseq.com

Terms and Provisions

1. If Purchaser contemporaneously herewith or subsequently executes a security agreement or a lease agreement relating to the Equipment described on the face hereof (herein called "Equipment"), the terms and provisions of such security agreement or lease Agreement shall supersede all terms and provisions of this Equipment Order and Agreement (herein called "Agreement"). Without limiting the generality of the foregoing, if this agreement is superseded by a lease agreement, all payments made hereunder shall be determined to be rental, and Purchaser shall not be deemed to have acquired any equity in the Equipment.
2. Subject to the provisions of Paragraph 1, Seller agrees to sell and Purchaser agrees to purchase the Equipment for the price or prices and on the terms and conditions stated on the face hereof and on this page 2. Unless otherwise specified, the terms of this agreement are net cash on receipt of invoice. If payment is not made on or before the due date, the full unpaid balance shall, at Seller's option, be subject to interest until paid at the rate of 1 1/2% per month if Purchaser is a corporation or at the highest legal rate permitted by law if the Purchaser is a partnership or an individual. Neither the loss, destruction, or damage of the Equipment, nor the renewal or extension of this contract, nor the institution of suit or procurement or judgement thereon; nor the hypothecation, assignment or discounting of this Agreement shall operate as payment or in any manner relieve Purchaser from his obligations hereunder.
3. To secure the performance of Purchaser's obligations under this Agreement, Purchaser hereby grants to Seller a security interest in the Equipment, effective upon delivery of the Equipment to Purchaser. Such interest shall be enforceable by Seller in accordance with the provisions of Article IX of the Minnesota Uniform Commercial Code. Until Purchaser has performed all obligations on the part of Purchaser to be performed under this Agreement, Purchaser agrees: (a) to keep the Equipment in good condition and repair at his own expense; (b) not to assign or transfer any interest in this Agreement, nor sell, assign, pledge, mortgage, encumber, suffer the creation of any lien, nor dispose of the Equipment or any part thereof, nor make any material change in Equipment, without the prior written consent of Seller; (c) to pay all taxes, charges and assessments of every character levied or assessed against the Equipment; (d) to keep the Equipment insured at his own expense, against all physical loss or damage, of whatsoever kind and nature and however caused, excepting only loss or damage occasioned by so-called uninsurable perils, such as war risk, nuclear energy peril and normal wear and tear, in an amount not less than the remaining balance due to the Seller with deductible amount not to exceed \$1,000.00 per loss, and to place such insurance through agencies or brokers and with insurance companies acceptable to Seller, with the proceeds thereon payable to Seller and Purchaser as their interest may appear; (e) to execute all documents which may be necessary for the perfection and recording of Seller's security interest in the Equipment.
4. Purchaser shall pay all transportation charges. Within five (5) days after delivery of the Equipment at the point of destination, Purchaser shall notify Seller in writing of any claimed defects in the Equipment or of any claimed failure by Seller to comply with its promises and obligations concerning the Equipment. If such notice in writing is not given to Seller by Purchaser within said time, then the Equipment shall be deemed to have been accepted by Purchaser and to be in full compliance with all terms, conditions, covenants and representations herein contained. Purchaser will ensure all persons operating equipment will have read the equipment operator's manual. If unable to locate, please contact the Seller to request a copy.
5. Purchaser may not return the Equipment without the written consent of Seller. If Seller consents in writing to such return, a charge of 10 percent may be made to Purchaser to cover handling expenses, except for Equipment found upon return to have been defective.
6. Seller shall not be liable to Purchaser if Seller cannot obtain the Equipment through the exercise of reasonable diligence, or if delivery is delayed or prevented by the manufacturer or by strike, accident, act of God, war, civil commotion or riot, governmental action or requirement, or other cause beyond the control of Seller. Seller assumes no responsibility and shall not be liable for any loss or damages, direct or consequential, alleged to have been caused by or resulting from the operation or non-operability of the Equipment.
7. If any equipment owned by Purchaser is to be traded in as part of this Agreement, but the same is not to be delivered to Seller until a time later than the date of this Agreement, Seller shall have the right to reappraise said trade-in equipment at the time of actual delivery to Seller, and said reappraisal value shall determine the Trade-In Allowance for said equipment.
8. PURCHASER ACKNOWLEDGES: (a) THAT PURCHASER MAKES THE FINAL SELECTION, IN ALL RESPECTS, OF THE EQUIPMENT; (b) THAT SELLER IS NOT A MANUFACTURER OF THE EQUIPMENT; (c) THAT PURCHASER ACCEPTS THE EQUIPMENT WITH ALL FAULTS, SUBJECT ONLY TO MANUFACTURERS AND/OR DEALER'S WRITTEN NEW EQUIPMENT WARRANTIES, IF ANY; (d) THAT UNLESS OTHERWISE SPECIFICALLY STATED ON THE FACE HEREOF, USED EQUIPMENT IS NOT SUBJECT TO ANY WARRANTY BY MANUFACTURER OR SELLER; (e) THAT NOTWITHSTANDING ANY WARRANTY, IF ANY, BY THE MANUFACTURER AND/OR SELLER, NEITHER MANUFACTURER NOR SELLER SHALL BE LIABLE FOR THE COST OF REPAIRS MADE OUTSIDE OF SELLER'S OR MANUFACTURER'S PLACE OF BUSINESS, UNLESS AUTHORIZED IN WRITING; (f) THAT THERE ARE NO WARRANTIES - EXPRESS, IMPLIED OR STATUTORY - ON THE PART OF SELLER AS TO FITNESS OF THE EQUIPMENT FOR ANY GENERAL OR SPECIFIC PURPOSE OR AS TO MERCHANTABILITY OR QUALITY; (g) NO PAYMENT REQUIRED HEREUNDER TO BE MADE BY PURCHASER SHALL BE DELAYED AWAITING SETTLEMENT OF ANY CLAIM.
9. If upon tender of delivery of the Equipment by Seller to Purchaser, Purchaser fails or refuses for any reason to complete the purchase transaction, Seller may in its discretion retain the Down Payment and the trade-in equipment as liquidated damages; or, at its option, Seller may resell or retain the trade-in equipment, and shall apply the Down Payment and the amount received on resale, or the fair market value of said equipment (if no resale) as of the date of Purchaser's breach, in reduction of Seller's damages, costs and expenses.
10. The following shall be deemed to be events of default by Purchaser: (a) the failure by Purchaser to comply with any term or provision of this Agreement, (b) the failure by Purchaser to make any payment provided for herein when due or payable; (c) any cessation or interruption of Purchaser's business as a going concern; (d) any assignment by Purchaser for the benefit of creditors; (e) any assignment or purported assignment by Purchaser, whether voluntary or by operation of law, of Purchaser's interest in the Equipment without the prior written consent of Seller; (f) the institution of any proceeding under the Bankruptcy Act, voluntary or involuntary, by or against Purchaser; (g) the commencement of any insolvency or receivership proceeding, voluntary or involuntary, against Purchaser; (h) the levy upon or seizure by judicial process of the Equipment or any part thereof; (i) the occurrence of any unusual or unreasonable depreciation in the value of the Equipment arising out of its use by Purchaser; or (j) the determination by Seller that it is insecure, for whatever reason, with respect to the Equipment or PURCHASER'S obligations hereunder. Upon Purchaser's default, the entire unpaid balance of the purchase price, together with accrued interest thereon and all other sums payable hereunder, at the option of the Seller and without notice, shall become immediately due and payable and Seller may exercise all rights and remedies available to it under the Minnesota Uniform Commercial Code as now enacted or as may be from time to time amended, and, in conjunction with, and in addition to or substitution for those rights and remedies, at Seller's discretion, Seller may, in conformity with law, and without liability to purchaser therefore, (a) enter upon Purchaser's premises to take possession of, assemble and collect the Equipment or to render it unusable, or (b) require purchaser to assemble the Equipment and make it available at a place Seller designates which is mutually convenient to allow Seller to take possession or dispose of the Equipment.
11. Purchaser agrees to pay Seller or its assignees the reasonable expenses of retaking, holding, preparing for sale, selling, and the like, and the reasonable attorney's fees and legal expenses incurred by Seller or said assignees in recovering possession of the equipment or in collecting any installment or the unpaid balances of the purchase price. If Purchaser fails to pay any installment or the unpaid balance when due, Seller or its assignees may refer the collection thereof to any person or collection agency or to any of the employees of Seller or its assignees, and Purchaser agrees to Pay Seller or its assignees a reasonable collection charge, which shall in no event be less than 5 percent of said delinquent installment or unpaid balance, or \$150.00 whichever is the greater.
12. The failure of Seller in any one or more instances to insist upon the performance of any term or provision of this Agreement or to exercise any right or privilege conferred by this Agreement, shall not be construed as thereafter waiving any such term, provision, right or privilege.

* Subject to all applicable taxes. This proposal is good for 30 days and subject to availability. Pricing is subject to change without notice.



Savage, MN • 952-895-9595
Duluth, MN • 218-727-8611
Virginia, MN • 218-741-9011

Negaunee, MI • 906-475-6488
Des Moines, IA • 515-282-0404
Cedar Rapids, IA • 319-363-9655

Sioux City, IA • 712-252-0538
East Moline, IL • 309-755-7203
Rochester, MN • 507-701-0199



rmsequipment.com



JOHN DEERE

Investment Proposal (Quote)

RDO Equipment Co.
1710 East College Drive
Marshall MN, 56258
Phone: (507) 532-0994 - Fax: (507) 532-0993

Proposal for:
CITY OF REDWOOD FALLS
333 SOUTH WASHINGTON
PO BOX 526
REDWOOD FALLS, MN, 56283
REDWOOD

Investment Proposal Date: 2/1/2023
Pricing Valid Until: 2/15/2023
Deal Number: 1582968
Customer Account#: 5755014
Sales Professional: John Bot
Phone: (507) 532-0994
Fax: (507) 532-0993
Email: JBot@rdoequipment.com

Equipment Information

Quantity	Serial Number Stock Number	Hours (approx.)	Status / Year / Make / Model Additional Items	Cash Price
1	H2510264 X997513	87	New 2021 HAMM HD12IVV	\$55,362.40

0020 STANDARD COLOR (RAL2004 + RAL 7015)
 0030 VERSION WITH CE CONFORMITY
 0040 WARNING LABELS ACCORDING TO ANSI
 0050 PLASTIC SCRAPER, FOLDABLE
 0060 ROPS FOLDABLE
 0070 DRIVER SEAT BLACK IMITATION LEATHER
 0080 2071611 LIGHTING PACKAGES AS PER ROAD TRAFFIC
 REGULATIONS
 0090 HYDRAULIC OIL
 0100 ENGLISH SPARE PARTS & APPLICATION DOCS (EN)
 0110 TECHNICAL DOCUMENTATION USA
 0120 2653020 BACK-UP ALARM
 0130 V BELT PROTECTION
 0140 USA OPERATION

Equipment Subtotal: \$55,362.40

Trade Information

Serial Number	Year / Make / Model	Payoff Information	Trade In Hours	Trade In Value
146151	1997 INGERSOLL RAND DD-24	\$0.00	1817	(\$5,000.00)
Total Trade in Value:				(\$5,000.00)
Trade Balance Owed:				\$0.00
Net Difference:				(\$5,000.00)

Purchase Order Totals

Balance: \$50,362.40
 Total Taxable Amount: \$0.00
 MN STATE TAX: \$0.00
 MN SPECIAL TAX: \$0.00
 Sales Tax Total: \$0.00
 Sub Total: \$50,362.40
 Cash with Order: \$0.00
 Balance Due: \$50,362.40

HEAVY EQUIPMENT GUIDE

TANDEM ASPHALT ROLLERS

HD 12 VV

HAMM AG



The HD 12 VV is an articulated tandem roller with 2 vibratory drums. It comes equipped with a 3-point swivel joint for optimum driving comfort, a central suspension point, and an optimum front view due to a concaving front end.

SPECS

Key Specifications

Operating weight with ROPS	5,942.47lbs (2,695kg)
Drum width	47.24in (1,200mm)
Power rat. ISO 14396	18,5 kW / 25,2 PS / 2200 rpm



Darrell Bowers
Street Department Superintendent
Phone: 507-616-7477
Cell: 507-317-1890
dbowers@ci.redwood-falls.mn.us

Meeting Date: May 16, 2023

AGENDA RECOMMENDATION

Agenda Item: 2023 Crew Cab Pickup Purchase with Olson Chevrolet

Recommendation/Action Requested: Staff recommends approval of the proposal from Olson Chevrolet to purchase a 2023 pickup truck and declare 2012 pickup truck surplus property.

Summary/Overview: The 2023 Central Garage Operating Budget includes selling a 2012 Pickup (Electric Department). Staff requests approval to purchase the 2023 Chevrolet Silverado 2500 Crew Cab 172" Work Truck from Olson Chevrolet for \$50,850.35 and declare the 2012 pickup surplus property.

Attachments: Olson Chevrolet Proposal – \$50,850.35
Weelborg Ford Proposal – \$56,186.00



Vehicle: [Retail] 2023 Chevrolet Silverado 2500HD (CK20943) 4WD Crew Cab 172" Work Truck (Complete)

Window Sticker

SUMMARY

[Retail] 2023 Chevrolet Silverado 2500HD (CK20943) 4WD Crew Cab 172" Work Truck

MSRP:\$48,700.00

Interior:Jet Black, Cloth seat trim

Exterior 1:Summit White

Exterior 2:No color has been selected.

Engine, 6.6L V8

Transmission, 6-speed automatic, heavy-duty

OPTIONS

CODE	MODEL	MSRP
CK20943	[Retail] 2023 Chevrolet Silverado 2500HD (CK20943) 4WD Crew Cab 172" Work Truck	\$48,700.00
OPTIONS		
1WT	Work Truck Preferred Equipment Group	\$0.00
9L7	Upfitter switch kit, (5)	\$150.00
AE7	Seats, front 40/20/40 split-bench	\$0.00
AKO	Glass, deep-tinted	Inc.
AQQ	Remote Keyless Entry	Inc.
C49	Defogger, rear-window electric	Inc.
DD8	Mirror, inside rearview auto-dimming	Inc.
DWC	Mirrors, outside power-adjustable vertical trailing with heated and auto-dimming upper glass	\$430.00
E63	Durabed, pickup bed	\$0.00
FE9	Emissions, Federal requirements	\$0.00
GAZ	Summit White	\$0.00
GT4	Rear axle, 3.73 ratio	\$0.00
H1T	Jet Black, Cloth seat trim	\$0.00
IOR	Audio system, Chevrolet Infotainment 3 system	\$0.00
JGF	GVWR, 10,650 lbs. (4831 kg)	\$0.00
JL1	Trailer brake controller, integrated	\$275.00
K34	Cruise control, electronic	Inc.

This document contains information considered Confidential between GM and its Clients uniquely. The information provided is not intended for public disclosure. Prices, specifications, and availability are subject to change without notice, and do not include certain fees, taxes and charges that may be required by law or vary by manufacturer or region. Performance figures are guidelines only, and actual performance may vary. Photos may not represent actual vehicles or exact configurations. Content based on report preparer's input is subject to the accuracy of the input provided.

Data Version: 19334. Data Updated: May 3, 2023 6:40:00 PM PDT.



Vehicle: [Retail] 2023 Chevrolet Silverado 2500HD (CK20943) 4WD Crew Cab 172" Work Truck (Complete)

KC9	Power outlet, bed mounted, 120-volt	Inc.	
KI4	Power outlet, instrument panel, 120-volt		\$225.00
L8T	Engine, 6.6L V8		\$0.00
MYD	Transmission, 6-speed automatic, heavy-duty		\$0.00
PCV	WT Convenience Package		\$975.00
PYN	Wheels, 17" (43.2 cm) painted steel, Silver		\$0.00
QHJ	Tires, LT245/75R17E all-season, blackwall		\$0.00
QT5	Tailgate, gate function manual with EZ Lift	Inc.	
ZHQ	Tire, spare LT245/75R17E all-season, blackwall		\$0.00
SUBTOTAL			\$50,755.00
Adjustments Total			\$0.00
Destination Charge			\$1,895.00
TOTAL PRICE			\$52,650.00

FUEL ECONOMY

Est City:N/A

Est Highway:N/A

Est Highway Cruising Range:N/A

This document contains information considered Confidential between GM and its Clients uniquely. The information provided is not intended for public disclosure. Prices, specifications, and availability are subject to change without notice, and do not include certain fees, taxes and charges that may be required by law or vary by manufacturer or region. Performance figures are guidelines only, and actual performance may vary. Photos may not represent actual vehicles or exact configurations. Content based on report preparer's input is subject to the accuracy of the input provided.

Data Version: 19334. Data Updated: May 3, 2023 6:40:00 PM PDT.



Vehicle: [Retail] 2023 Chevrolet Silverado 2500HD (CK20943) 4WD Crew Cab 172" Work Truck (✓
Complete)

Price Summary

PRICE SUMMARY

	Invoice	MSRP
Base Price	\$46,070.20	\$48,700.00
Total Options	\$1,870.05	\$2,055.00
Vehicle Subtotal	\$47,940.25	\$50,755.00
Dealer Advertising Adjustment	\$1,015.10	\$0.00
Destination Charge	\$1,895.00	\$1,895.00
Grand Total	\$50,850.35	\$52,650.00

*Gr Fleet -
whatever (res)
IS*

This document contains information considered Confidential between GM and its Clients uniquely. The information provided is not intended for public disclosure. Prices, specifications, and availability are subject to change without notice, and do not include certain fees, taxes and charges that may be required by law or vary by manufacturer or region. Performance figures are guidelines only, and actual performance may vary. Photos may not represent actual vehicles or exact configurations. Content based on report preparer's input is subject to the accuracy of the input provided.
Data Version: 19334. Data Updated: May 3, 2023 6:40:00 PM PDT.



Preview Order 1890 - W2B 4x4 Crew Cab SRW: Order Summary Time of Preview: 03/31/2023 10:03:16 Receipt: NA

Dealership Name: Weelborg Ford, Inc.

Sales Code : F58665

Dealer Rep. joel read	Type	Stock	Vehicle Line	Superduty	Order Code 1890
Customer Name	Priority Code 80		Model Year 2023		Price Level 335

DESCRIPTION	MSRP	DESCRIPTION	MSRP
F250 4X4 CREW CAB PICKUP/176	\$50770	.EBONY BLACK ALUM WHLS-18"	\$0
176 INCH WHEELBASE	\$0	.BOXLINK	\$0
OXFORD WHITE	\$0	.LED BOX LIGHTING	\$0
MEDIUM DARK SLATE	\$0	.PAYLOAD PACKAGE UPGRADE	\$0
PREFERRED EQUIPMENT PKG.600A	\$0	.REVERSE SENSING SYSTEM	\$0
.XL TRIM	\$0	.360-DEGREE CAMERA PACKAGE	\$0
.AIR CONDITIONING -- CFC FREE	\$0	.CLOTH 40/20/40 SEAT	\$0
.AM/FM STEREO MP3/CLK	\$0	.10600# GVWR PACKAGE	\$0
7.3L DEVCT NA PFI V8 ENGINE	\$1705	50 STATE EMISSIONS	\$0
10-SPEED AUTO TORQSHIFT	\$0	JACK	\$0
3.73 RATIO REGULAR AXLE	\$0	REMOTE START SYSTEM	\$250
JOB #2 ORDER	\$0	XL DRIVER ASSIST PACKAGE	\$0
CV LOT MANAGEMENT	\$0	FUEL CHARGE	\$0
STX APPEARANCE PACKAGE	\$5115	PRICED DORA	\$0
.LT275/70R18E BSW ALL TERRAIN	\$0	ADVERTISING ASSESSMENT	\$0
.BLIS (BLIND SPOT INFO SYSTEM)	\$0	DESTINATION & DELIVERY	\$1895
TOTAL BASE AND OPTIONS			MSRP \$59735
DISCOUNTS			NA
TOTAL			\$59735

56,186. - + tax, Lic

Customer Name:
Customer Address:

Customer Email:
Customer Phone:

Customer Signature _____ Date

This order has not been submitted to the order bank.

This is not an invoice.

Meeting Date: May 16, 2023

AGENDA RECOMMENDATION

Agenda Item: 2023 Reg Cab Pickup Purchase with Olson Chevrolet

Recommendation/Action Requested: Staff recommends approval of the proposal from Olson Chevrolet to purchase a 2023 pickup truck and declare 2008 pickup truck surplus property.

Summary/Overview: The 2023 Central Garage Operating Budget includes selling a 2008 Pickup (Street Department). Staff requests approval to purchase the 2023 Chevrolet Silverado 2500 Reg Cab 142" Work Truck from Olson Chevrolet for \$46,781.30 and declare the 2008 pickup surplus property.

Attachments: Olson Chevrolet Proposal – \$46,781.30
Weelborg Ford Proposal – \$50,833.00



Vehicle: [Retail] 2023 Chevrolet Silverado 2500HD (CK20903) 4WD Reg Cab 142" Work Truck (✓
Complete)

Window Sticker

SUMMARY

[Retail] 2023 Chevrolet Silverado 2500HD (CK20903) 4WD Reg Cab 142" Work Truck

MSRP:\$44,300.00

Interior:Jet Black, Cloth seat trim

Exterior 1:Red Hot

Exterior 2:No color has been selected.

Engine, 6.6L V8

Transmission, 6-speed automatic, heavy-duty

OPTIONS

CODE	MODEL	MSRP
CK20903	[Retail] 2023 Chevrolet Silverado 2500HD (CK20903) 4WD Reg Cab 142" Work Truck	\$44,300.00
OPTIONS		
1WT	Work Truck Preferred Equipment Group	\$0.00
9L7	Upfitter switch kit, (5)	\$150.00
AE7	Seats, front 40/20/40 split-bench	\$0.00
AED	Window, power front, passenger express down	Inc.
AKO	Glass, deep-tinted	Inc.
AQQ	Remote Keyless Entry	Inc.
AU3	Door locks, power	Inc.
AXG	Window, power front, drivers express up/down	Inc.
C49	Defogger, rear-window electric	Inc.
DBG	Mirrors, outside power-adjustable vertical trailing	Inc.
E63	Durabed, pickup bed	\$0.00
FE9	Emissions, Federal requirements	\$0.00
G7C	Red Hot	\$0.00
GT4	Rear axle, 3.73 ratio	\$0.00
H1T	Jet Black, Cloth seat trim	\$0.00
IOR	Audio system, Chevrolet Infotainment 3 system	\$0.00
JGB	GVWR, 10,250 lbs. (4649 kg)	\$0.00
JL1	Trailer brake controller, integrated	\$275.00

This document contains information considered Confidential between GM and its Clients uniquely. The information provided is not intended for public disclosure. Prices, specifications, and availability are subject to change without notice, and do not include certain fees, taxes and charges that may be required by law or vary by manufacturer or region. Performance figures are guidelines only, and actual performance may vary. Photos may not represent actual vehicles or exact configurations. Content based on report preparer's input is subject to the accuracy of the input provided.

Data Version: 19334. Data Updated: May 3, 2023 6:40:00 PM PDT.



Vehicle: [Retail] 2023 Chevrolet Silverado 2500HD (CK20903) 4WD Reg Cab 142" Work Truck (✓
Complete)

K34	Cruise control, electronic	Inc.	
L8T	Engine, 6.6L V8		\$0.00
MYD	Transmission, 6-speed automatic, heavy-duty		\$0.00
PCV	WT Convenience Package		\$1,825.00
PYN	Wheels, 17" (43.2 cm) painted steel, Silver		\$0.00
QHJ	Tires, LT245/75R17E all-season, blackwall		\$0.00
QT5	Tailgate, gate function manual with EZ Lift	Inc.	
ZHQ	Tire, spare LT245/75R17E all-season, blackwall		\$0.00
SUBTOTAL			\$46,550.00
Adjustments Total			\$0.00
Destination Charge			\$1,895.00
TOTAL PRICE			\$48,445.00

FUEL ECONOMY

Est City:N/A

Est Highway:N/A

Est Highway Cruising Range:N/A

This document contains information considered Confidential between GM and its Clients uniquely. The information provided is not intended for public disclosure. Prices, specifications, and availability are subject to change without notice, and do not include certain fees, taxes and charges that may be required by law or vary by manufacturer or region. Performance figures are guidelines only, and actual performance may vary. Photos may not represent actual vehicles or exact configurations. Content based on report preparer's input is subject to the accuracy of the input provided.

Data Version: 19334. Data Updated: May 3, 2023 6:40:00 PM PDT.



Vehicle: [Retail] 2023 Chevrolet Silverado 2500HD (CK20903) 4WD Reg Cab 142" Work Truck (✓
Complete)

Price Summary

PRICE SUMMARY

	Invoice	MSRP
Base Price	\$41,907.80	\$44,300.00
Total Options	\$2,047.50	\$2,250.00
Vehicle Subtotal	\$43,955.30	\$46,550.00
Dealer Advertising Adjustment	\$931.00	\$0.00
Destination Charge	\$1,895.00	\$1,895.00
Grand Total	\$46,781.30	\$48,445.00

*This or
Fleet
whatever
less*

This document contains information considered Confidential between GM and its Clients uniquely. The information provided is not intended for public disclosure. Prices, specifications, and availability are subject to change without notice, and do not include certain fees, taxes and charges that may be required by law or vary by manufacturer or region. Performance figures are guidelines only, and actual performance may vary. Photos may not represent actual vehicles or exact configurations. Content based on report preparer's input is subject to the accuracy of the input provided.

Data Version: 19334. Data Updated: May 3, 2023 6:40:00 PM PDT.



Preview Order 1890 - F2B 4x4 Reg Cab SRW: Order Summary Time of Preview: 03/31/2023 10:27:31 Receipt: NA

Dealership Name: Weelborg Ford, Inc.

Sales Code : F58665

Dealer Rep.	joel read	Type	Stock	Vehicle Line	Superduty	Order Code	1890
Customer Name		Priority Code	80	Model Year	2023	Price Level	335

DESCRIPTION	MSRP	DESCRIPTION	MSRP
F250 4X4 STYLESIDE PICKUP/142	\$46760	.EBONY BLACK ALUM WHLS-18"	\$0
142 INCH WHEELBASE	\$0	.BOXLINK	\$0
RACE RED	\$0	.LED BOX LIGHTING	\$0
MEDIUM DARK SLATE	\$0	.PAYLOAD PACKAGE UPGRADE	\$0
PREFERRED EQUIPMENT PKG.600A	\$0	.REVERSE SENSING SYSTEM	\$0
.XL TRIM	\$0	.360-DEGREE CAMERA PACKAGE	\$0
.AIR CONDITIONING -- CFC FREE	\$0	.CLOTH 40/20/40 SEAT	\$0
.AM/FM STEREO MP3/CLK	\$0	10300# GVWR PACKAGE	\$0
.6.8L DEVCT NA PFI V8 ENGINE	\$0	50 STATE EMISSIONS	\$0
10-SPEED AUTO TORQSHIFT-G	\$0	JACK	\$0
3.73 RATIO REGULAR AXLE	\$0	REMOTE START SYSTEM	\$250
JOB #2 ORDER	\$0	XL DRIVER ASSIST PACKAGE	\$0
CV LOT MANAGEMENT	\$0	FUEL CHARGE	\$0
STX APPEARANCE PACKAGE	\$5115	PRICED DORA	\$0
.LT275/70R18E BSW ALL TERRAIN	\$0	ADVERTISING ASSESSMENT	\$0
.BLIS (BLIND SPOT INFO SYSTEM)	\$0	DESTINATION & DELIVERY	\$1895
TOTAL BASE AND OPTIONS			MSRP \$54020
DISCOUNTS			NA
TOTAL			\$54020

\$50,833. - + tax Lic fees

Customer Name:
Customer Address:

Customer Email:
Customer Phone:

Customer Signature

Date

This order has not been submitted to the order bank.

This is not an invoice.

Meeting Date: May 16, 2023

AGENDA RECOMMENDATION

Agenda Item: 2023 Double Cab Pickup Purchase with Olson Chevrolet and Utility Box Purchase from Crysteel Truck Equipment

Recommendation/Action Requested: Staff recommends approval of the proposal from Olson Chevrolet to purchase a 2023 pickup truck, approval of the proposal from Crysteel Truck Equipment to purchase a utility box and declare 2011 pickup truck surplus property.

Summary/Overview: The 2023 Central Garage Operating Budget includes selling a 2011 Pickup (Water Department). Staff requests approval to purchase the 2023 Chevrolet Silverado 2500 Double Cab 162" Work Truck from Olson Chevrolet for \$47,228.30 and a utility box from Crysteel Truck Equipment for \$20,336.00 and declare the 2011 pickup surplus property.

Attachments: Olson Chevrolet Proposal – \$47,228.30
Weelborg Ford Proposal – \$51,405.00

Utility Box Quotes
Crysteel Truck Equipment – \$20,336.00
Northern Truck Equipment – \$21,071.00



Vehicle: [Retail] 2023 Chevrolet Silverado 2500HD (CK20953) 4WD Double Cab 162" Work Truck (Complete)

Window Sticker

SUMMARY

[Retail] 2023 Chevrolet Silverado 2500HD (CK20953) 4WD Double Cab 162" Work Truck

MSRP:\$46,900.00

Interior:Jet Black, Cloth seat trim

Exterior.1:Summit White

Exterior.2:No color has been selected.

Engine, 6.6L V8

Transmission, 6-speed automatic, heavy-duty

OPTIONS

CODE	MODEL	MSRP
CK20953	[Retail] 2023 Chevrolet Silverado 2500HD (CK20953) 4WD Double Cab 162" Work Truck	\$46,900.00
OPTIONS		
1WT	Work Truck Preferred Equipment Group	\$0.00
9J4	Bumper, rear, delete	Inc.
9L3	Spare tire delete	Inc.
9L7	Upfitter switch kit, (5)	\$150.00
AE7	Seats, front 40/20/40 split-bench	\$0.00
AKO	Glass, deep-tinted	Inc.
AQQ	Remote Keyless Entry	Inc.
C49	Defogger, rear-window electric	Inc.
C7G	GVWR, 10,500 lbs. (4763 kg)	\$0.00
DBG	Mirrors, outside power-adjustable vertical trailinging	Inc.
FE9	Emissions, Federal requirements	\$0.00
GAZ	Summit White	\$0.00
GT4	Rear axle, 3.73 ratio	\$0.00
H1T	Jet Black, Cloth seat trim	\$0.00
IOR	Audio system, Chevrolet Infotainment 3 system	\$0.00
K34	Cruise control, electronic	Inc.
L8T	Engine, 6.6L V8	\$0.00
MYD	Transmission, 6-speed automatic, heavy-duty	\$0.00

This document contains information considered Confidential between GM and its Clients uniquely. The information provided is not intended for public disclosure. Prices, specifications, and availability are subject to change without notice, and do not include certain fees, taxes and charges that may be required by law or vary by manufacturer or region. Performance figures are guidelines only, and actual performance may vary. Photos may not represent actual vehicles or exact configurations. Content based on report preparer's input is subject to the accuracy of the input provided.

Data Version: 19334. Data Updated: May 3, 2023 6:40:00 PM PDT.



Vehicle: [Retail] 2023 Chevrolet Silverado 2500HD (CK20953) 4WD Double Cab 162" Work Truck (Complete)

PCV	WT Convenience Package		\$1,035.00
PYN	Wheels, 17" (43.2 cm) painted steel, Silver		\$0.00
QHQ	Tires, LT245/75R17E all-season, blackwall		\$0.00
SFW	Back-up alarm calibration	Inc.	
ZW9	Pickup bed, delete		(\$1,155.00)
—	Capped Fuel Fill	Inc.	
SUBTOTAL			\$46,930.00
Adjustments Total			\$0.00
Destination Charge			\$1,895.00
TOTAL PRICE			\$48,825.00

FUEL ECONOMY

Est City:N/A

Est Highway:N/A

Est Highway Cruising Range:N/A

This document contains information considered Confidential between GM and its Clients uniquely. The information provided is not intended for public disclosure. Prices, specifications, and availability are subject to change without notice, and do not include certain fees, taxes and charges that may be required by law or vary by manufacturer or region. Performance figures are guidelines only, and actual performance may vary. Photos may not represent actual vehicles or exact configurations. Content based on report preparer's input is subject to the accuracy of the input provided.

Data Version: 19334. Data Updated: May 3, 2023 6:40:00 PM PDT.



Vehicle: [Retail] 2023 Chevrolet Silverado 2500HD (CK20953) 4WD Double Cab 162" Work Truck (✓ Complete)

Price Summary

PRICE SUMMARY

	Invoice	MSRP
Base Price	\$44,367.40	\$46,900.00
Total Options	\$27.30	\$30.00
Vehicle Subtotal	\$44,394.70	\$46,930.00
Dealer Advertising Adjustment	\$938.60	\$0.00
Destination Charge	\$1,895.00	\$1,895.00
Grand Total	\$47,228.30	\$48,825.00

or Fleet
Whatever FS
has

This document contains information considered Confidential between GM and its Clients uniquely. The information provided is not intended for public disclosure. Prices, specifications, and availability are subject to change without notice, and do not include certain fees, taxes and charges that may be required by law or vary by manufacturer or region. Performance figures are guidelines only, and actual performance may vary. Photos may not represent actual vehicles or exact configurations. Content based on report preparer's input is subject to the accuracy of the input provided.

Data Version: 19334. Data Updated: May 3, 2023 6:40:00 PM PDT.



Preview Order 1890 - X2B 4x4 Super Cab SRW: Order Summary Time of Preview: 03/31/2023 10:00:21 Receipt: NA

Dealership Name: Weelborg Ford, Inc.

Sales Code: F58665

Dealer Rep.	joel read	Type	Stock	Vehicle Line	Superduty	Order Code	1890
Customer Name		Priority Code	80	Model Year	2023	Price Level	335

DESCRIPTION	MSRP	DESCRIPTION	MSRP
F250 4X4 SUPERCAB PICKUP/164	\$52955	JOB #2 ORDER	\$0
164 INCH WHEELBASE	\$0	CV LOT MANAGEMENT	\$0
OXFORD WHITE	\$0	10000# GVWR PACKAGE	\$0
40/20/40 CLOTH SEAT	\$0	50 STATE EMISSIONS	\$0
MEDIUM DARK SLATE	\$0	AM/FM STEREO MP3/CLK	\$0
PREFERRED EQUIPMENT PKG.603A	\$0	JACK	\$0
.XLT TRIM	\$0	REMOTE START SYSTEM	\$250
.7.3L DEVCT NA PFI V8 ENGINE	\$0	FUEL CHARGE	\$0
10-SPEED AUTO TORQSHIFT	\$0	PRICED DORA	\$0
LT275/65R18E BSW ALL SEASON	\$0	ADVERTISING ASSESSMENT	\$0
3.73 RATIO REGULAR AXLE	\$0	DESTINATION & DELIVERY	\$1895
TOTAL BASE AND OPTIONS			MSRP \$55100
DISCOUNTS			NA
TOTAL			\$55100

#52055

- 650 Bed Credit +

*51,405. - +, tax, Lic
fes*

Customer Name:
Customer Address:

Customer Email:
Customer Phone:

Customer Signature

Date

This order has not been submitted to the order bank.

This is not an invoice.



1130 73rd Avenue NE
 Fridley, MN 55432
 (763) 571-1902
 1-800-795-1902
 Fax # (763) 571-5091

Highway 60 East
 Lake Crystal, MN 56055
 (507) 726-6041
 1-800-722-0588
 Fax # (507) 726-2984

www.crysteeltruck.com

AN EQUAL OPPORTUNITY EMPLOYER

Date: 4/21/2023
 Company: City of Redwood Falls
 Contact: Darrell
 Phone#: 507-430-0059
 Email: dbowers@ci.redwood-falls.mn.us

Reference: RE\$V1
 Address:
 City: Redwood Falls
 State: MN

Dealer	Chassis Estimated Delivery		
Truck Make	Chevy	CA or CT	Long Box/56" CA
Model Year	2023/NEW	Transmission	
Truck Model	2500 GAS	Cab Color	

REFERENCE: COOPERATIVE PURCHASE OF EQUIPMENT FROM STATE OF MINNESOTA
 CONTRACT NO: 224099
 RELEASE NO: T-765(5)
 CONTRACT PERIOD: January 1, 2023, THROUGH, September 30, 2023
 EXTENSION OPTION: Up to 51 months
 1-UNIT
 STATE COOPERATIVE PRICING

QTY			Price Each	Extended
		2.0 Utility Service Body		
1	2.1	MCB 96" Series Model SB96M 4816 Specifications: 56" Single rear wheel application 42.5" high, 48-1/2" wide floor, 16" compartments, OA width 80-1/2" 25" floor to top of compartment, 19" radius, 53" UCA Street Side Compartments: 1st Vertical-32" wide x 42.5" high x 16" deep (1) (2) Adjustable Divider Tray (1) (2) Adjustable Shelf	\$10,240.00	\$10,240.00
1	2.25	DSP-1st Vertical Shelf (per shelf) Horizontal-42" wide x 21" high x 16" deep (1) Fixed Shelf-Centered Rear Vertical-22" wide x 42.5" high x 16" deep (1) Adjustable Shelf (1) False Wall to protect lights Curbside Compartments: 1st Vertical-32" wide x 42.5" high x 16" deep (1) (2) Adjustable Divider Tray (1) (2) Adjustable Shelf	\$118.00	\$118.00
1	2.25	DSP-1st Vertical Shelf (per shelf) Horizontal- 42" 64" x 21" high x 16" deep (1) Fixed Divider Tray Centered Vacant Rear Vertical-22" wide x 42.5" 21.5" high x 16" deep (1) False Wall to protect lights	\$118.00	\$118.00
1	NCI	Custom "I" Style Horizontal and Rear Vertical configuration	\$500.00	\$500.00

		Body Construction-14 gauge Galvanneal		
		Drain Holes in bottoms of all compartments		
		Compartment Tops-Smooth 14 gauge Galvanneal		
		Load space Walls-Smooth 14 gauge Galvanneal		
		Bulkhead-14 gauge Galvanneal		
		Wheel Panels-12 gauge Galvanneal		
		Rubber Fenders		
		Floor-12 gauge Galvanneal Treadplate		
		Underframe-10 gauge Formed Channel-E-Z Mount		
		(6) Body Doors-Double Panel		
		Outers-14 gauge Galvanneal beveled edge design		
		Inners-18 gauge Galvanneal		
		Installed using hidden hinge system		
		(6) Gasket-Clip on		
		(6) Rotary Paddle Handles-1 Point-Stainless Steel		
		(4) Spring Gas Shock Hold Open/Restrains on Vertical Doors		
4	2.31	FB-Add for gas door shocks (per compartment) for vertical doors	\$142.00	\$568.00
		(4) Chains on Horizontal Doors		
		Undercoating		
		Tailgate-12 gauge Galvanneal-Lift and Latch design, w/ support cables, and stainless pins and brackets		
		Primer-Standard Urethane-White		
		<i>Additional Add-ons</i>		
1	2.2	MGS-Installation	\$1,344.00	\$1,344.00
		Fleet White Color		
1	2.23	MGS-Add to undercoat 96" & 108" bodies	\$303.00	\$303.00
1	2.27	MGS-Add for Treadplate Bumper 8" x 80-1/2"	\$857.00	\$857.00
1	2.31	MGS-Add for recess in Treadplate Bumper	\$393.00	\$393.00
1	2.93	MGS-Add for Fuel filler hole ONLY	\$294.00	\$294.00
1	2.94	MGS-GM Underframe Mounting Kit	\$620.00	\$620.00
1	2.58	MGS-96" Roller Top-Galvanneal Steel-2 Section-48.5" wide floor	\$2,426.00	\$2,426.00
1	2.47	FB-Add for aluminum post for strobe (above cab top)	\$345.00	\$345.00
1	NCI	RECESSED LED AMBER STROBE INSTALLED IN REAR SIDE PACK	\$405.00	\$405.00
		<u>6.0 Hitches</u>		
1	6.1	Installation Buyers Service Body hitch	\$303.00	\$303.00
1	6.2	Buyers Service Body Hitch 2" Receiver 602-1801050L	\$314.00	\$314.00
1	6.7	7-way Plug	\$171.00	\$171.00
		<u>8.0 Accessories</u>		
1	8.38	For 1 Set Buyers Surface Mt Strobes	\$284.00	\$284.00
		*(1) Set Mounted In front Grill		
1	8.9	Repositions Camera Eye Only	\$300.00	\$300.00
1	8.29	Buyers Mini Light Bar installed on cab shield, wired to in dash switch	\$433.00	\$433.00
		NCI Select Accessory		

Total Package Price

\$20,336.00

PRICES SHOWN DO NOT INCLUDE ANY APPLICABLE TAXES OR FEES

Cost Per Loaded Mile for Delivery:

\$4.00

Starting Point:

Lake Crystal, MN

*A WRITTEN PURCHASE ORDER MUST BE RETURNED SPECIFYING PURCHASE OF THIS EQUIPMENT OFF THE STATE OF MINNESOTA COOPERATIVE PURCHASE CONTRACT

*NO EXHAUST WORK INCLUDED FOR TRUCKS WITH NEW EMISSION CONTROL EXHAUST SYSTEMS. EXHAUST SYSTEMS CANNOT BE MODIFIED.

*ALL LABOR COSTS ARE BASED ON INSTALLING EQUIPMENT ON A TRUCK CHASSIS WITH ALL TRUCK ITEMS OUT OF THE WAY FOR EQUIPMENT INSTALLATION. IF CRYSTEEL HAS TO MOVE FUEL TANKS, AIR TANKS, AIR DRYER, ETC. EXTRA CHARGES MAY APPLY

Vendor Name:	Crysteel Truck Equipment-Lake Crystal
Contact Person:	Josh Miller
Street Address:	52248 Ember Rd
City, State, Zip:	Lake Crystal, MN 56055
Phone #:	(507) 726-6041
Toll Free #:	(800) 722-0588
Fax #:	(507) 726-2984
Email Address:	jmillier@crysteeltruck.com

OPTIONS -- The below options are NOT included in the above package pricing

<u>2.0 Utility Service Body OPTIONS</u>			
1	Trade Value for Chevy Long Box only	-\$800.00	-\$800.00
<u>8.0 Accessories OPTIONS</u>			
1	8.28 Dynamic Suspensions	\$726.00	\$726.00



"for over 84 years"

Northern Truck Equipment Corp.

P. O. Box 563 – Sioux Falls, SD 57101-0563 – Phone (605) 543-5206 – Fax: (605) 543-5219

P. O. Box 130 – Rapid City, SD 57709-0130 – Phone (605) 341-8780 – Fax: (605) 341-8786

P. O. Box 9675 – Fargo, ND 58106-9675 – Phone (701) 281-1718 – Fax: (701) 281-1859

www.ntecorp.com

email: sbentele@ntecorp.com

Quote

SF 114897

City Of Redwood Falls Street Department

DATE May 08, 2023

NAME Darrell Bowers

Redwood Falls, Minnesota

PHONE 507-616-7477 Cell: 507-317-1890

EMAIL dbowers@ci.redwood-falls.mn.us

WE PROPOSE TO FURNISH THE FOLLOWING FOR YOUR CONSIDERATION:

DELIVERY: To Be Determined

QUOTED F.O.B.

Sioux Falls, South Dakota

TERMS: Cash/Check

QUANTITY	DESCRIPTION	PRICE
1 Each	Knapheide Steel Service Body Model 796	
	700 Series (500 Series Configuration Curb Side, 600 Series Street Side)	
	Body Length: 97.25" - Body Height: 40" - Compartment Dept: 14.5"	
	Cargo Floor Width: 49" - E-Coat Primer	
	Two (2) Adjustable Divider Shelves And Dividers, Street And Curb Side Front Compartment	
	One (1) Adjustable Divider Shelf And Dividers, Full Height Rear Vertical Compartment	
	One (1) Adjustable Divider Shelf And Dividers, Curb Side Horizontal Compartment	
	Automotive Quality Rotary Latches And Double Spring Over Center Door Retainers On All Vertical Doors.	
	One (1) 12" Slam Tailgate - Weight: Approximately 1051 Lbs.	
1 Each	Knapheide 2 Section Telescopic Sliding Roof Model TSR96J	
	For 96" Standard Service Body - Installed	
1 Each	Knapheide Painted Service Body And Telescopic Sliding Roof – Knap White	
1 Each	Knapheide 78" Wide Knaplined Galva-Grip Bumper With Hitch Recess For Pickup Bed Removal With Factory Hitch	
1 Each	Knapheide L.E.D. Surface Mount Stop/Turn/Tail Lights For Steel Service Body	
1 Each	Knapheide Installation Kit For Steel Service Body	
1 Each	Fuel Fill Hose Kit For One (1) Fuel Tank System	
1 Each	Installation Of Above Equipment Onto Appropriate Customers Vehicle	
1 Each	F.O.B. Sioux Falls, South Dakota	\$19,837.00
	Due To The Volatility In The Markets, Prices Are Subject To Change At Any Time	
	Plus Applicable Taxes	
	3% Fee For Credit Cards	

QUOTATION FIRM FOR 15 DAYS

NORTHERN TRUCK EQUIPMENT CORP.

BY Steven Bentele

TITLE Sales

We accept the above quotation as a firm order, subject to confirmation from NTEC.

Buyer

(Name of Individual, Company or Political Subdivision)

(Name and Title of Official)

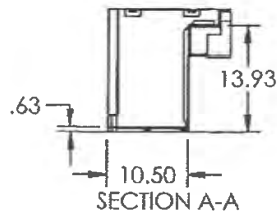
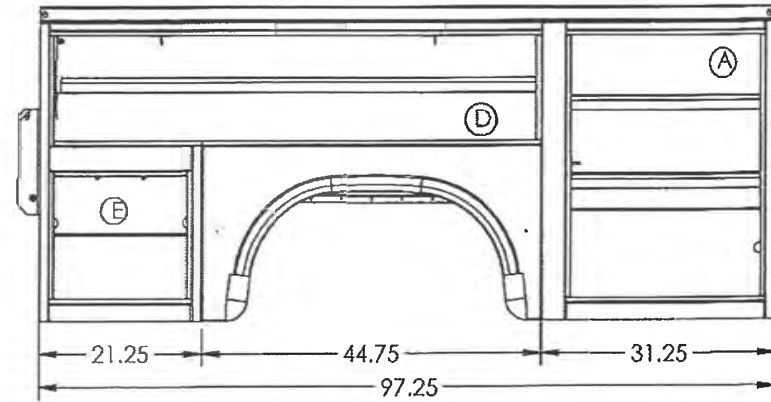
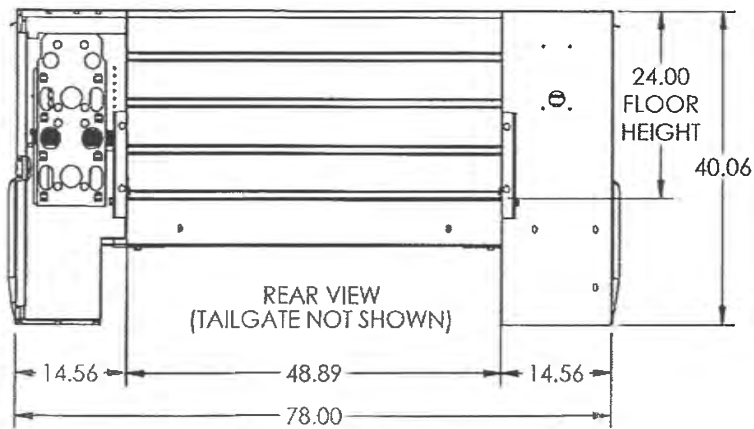

CURB SIDE & STREET SIDE FRONT COMPT.

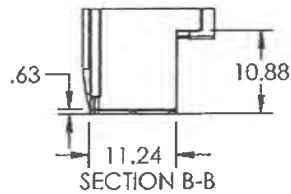

CURB SIDE & STREET SIDE REAR COMPT.

CLEAR DOOR OPENINGS					
	A	B	C	D	E
WIDTH	25.50	43.50	15.50	63.50	17.50
HEIGHT (STD)	33.50	13.50	33.50	13.50	15.50

- AUTOMOTIVE STYLE 2-STAGE ROTARY PADDLE LATCHES
- E-COAT PRIME

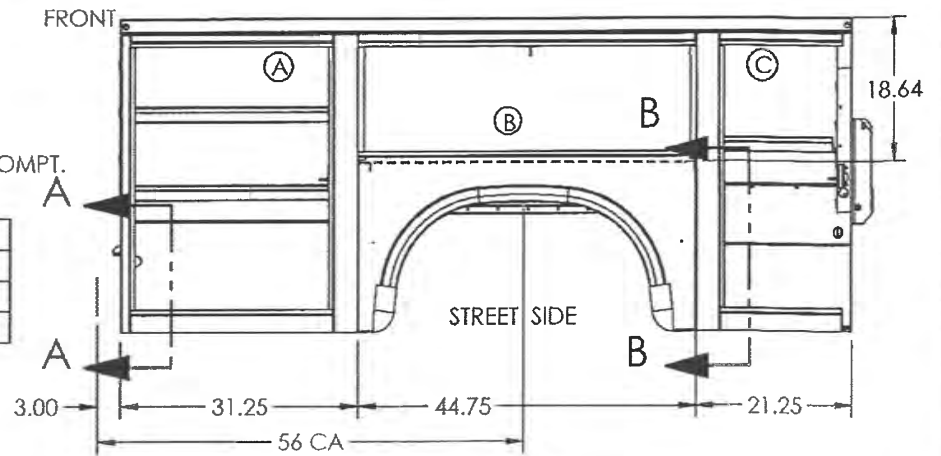

RELEASED, VERSION: 30

1	44357 #34B28562 REPLACES #20118390	NLOHMEYER	01/10/2023
REV	ECO	BY	DATE
CHANGE DESCRIPTION		REVISION STATUS	

KNAPHEIDE
SINCE 1848

PROPERTY OF KNAPHEIDE MFG. CO.
QUINCY, IL AND IS LOANED TO THE RECIPIENT
SUBJECT TO RETURN UPON DEMAND. ITS
CONTENTS ARE CONFIDENTIAL AND MUST NOT
BE COPIED OR SUBMITTED TO OUTSIDE PARTIES
FOR USE OR EXAMINATION.
UNLESS OTHERWISE SPECIFIED
THE FOLLOWING TOLERANCES APPLY

DESIGNATION	TOLERANCE
X	± 0.12
XX	± 0.05
XXX	± 0.03
ANGLES	± 2°

DRAWING TITLE:
BODY UTILITY 796 W&GR

MATERIAL:

CREATED BY: NL	CREATED ON: 10/4/2019
SIZE A	SCALE 1:24
REFERENCE DRAWING:	SHEET: 1 OF 1
PART NUMBER: 796	REV 1
ECO NO. 44357	

WEIGHT:
lbs



Ross Nachreiner
Redwood Falls Parks & Rec Director
Phone: 507-616-7444
Fax: 507-644-2199
rnachreiner@ci.redwood-falls.mn.us

AGENDA RECOMMENDATION

Council Meeting Date: May 16th, 2023

Agenda Item: Resolution No. 27 of 2023 – Resolution Accepting Donation for Volleyball Equipment

Recommendation/Action Requested: Read the proposed Resolution or make a motion to waive the reading of the Resolution. Discuss the proposed Resolution. If no concerns, adopt proposed Resolution by motion in accordance with Chapter 4 of the City Charter.

Summary/Overview: Attached is Resolution 27 of 2023 accepting a financial donation in the amount of \$3000.00 from the Redwood Area Junior Olympics volleyball association. The donation will be put towards the purchase of volleyball nets and various volleyball equipment that will be used jointly by the department and association.

Staff is requesting approval to accept the financial donation from the Redwood Area Juniors.

Attachments: Resolution No. 27 of 2023

RESOLUTION NO. 27 OF 2023
A RESOLUTION ACCEPTING A DONATION TO THE CITY.

WHEREAS, the City of Redwood Falls is generally authorized to accept donations of real and personal property pursuant to Minnesota Statutes Section 465.03 et seq. for the benefit of its citizens and is specifically authorized to accept gifts; and

WHEREAS, the following persons and entities have offered to contribute the cash amounts set forth below to the City:

<u>Name of Donor</u>	<u>Amount</u>
Redwood Area Junior Olympic Volleyball	\$3,000.00

WHEREAS, the terms or conditions of the donations, if any, are as follows:

Terms or Conditions
Contribution towards the purchase of Volleyball Equipment to be used at the Redwood Area Community Center.

WHEREAS, all such donations have been contributed to the City for the benefit of its citizens, as allowed by law; and

WHEREAS, the City Council finds that it is appropriate to accept the donations offered.

NOW THEREFORE, BE IT RESOLVED BY THE CITY COUNCIL OF THE CITY OF REDWOOD FALLS, MINNESOTA AS FOLLOWS:

1. The donations described above are accepted and shall be used to establish and/or operate services either alone or in cooperation with others, as allowed by law.
2. The city clerk is hereby authorized, if requested, to issue receipts to each donor acknowledging the city's receipt of the donor's donation.

PASSED AND ADOPTED by the City Council of the City of Redwood Falls, Minnesota this 16th day of May 2023.

ATTEST:

Keith Muetzel
City Administrator

Tom Quackenbush
Mayor

(City Seal)

Subscribed and sworn to before me this
16th day of May 2023.

Notary Public



Nuvera 

Nuvera Fiber Expansion Project Update

City of Redwood Falls

May 16, 2023

© 2023 Nuvera. All rights reserved.

1

Nuvera was founded in 1905 by farmers who wanted better access to the technology of the time - phone service.



2



Nuvera

Today Nuvera is a leading connections company delivering on that early vision to provide reliable, affordable access to today's technology in all the communities we serve.

3

About Nuvera: A Local Connections Company Providing State-of-the-Art Internet to Homes & Businesses

- ◆ Leadership
 - Glenn Zerbe, CEO/President
 - Barb Bornhoft, COO/Vice President
 - Curt Kawlewski, CFO
- ◆ Headquartered in New Ulm, MN
- ◆ Minnesota publicly held corporation
- ◆ Employees - 215
- ◆ Local offices - 11 located in southern MN and northern IA
- ◆ Serving over 70,000 voice, video and internet connections
- ◆ Fiber MN ownership – most comprehensive statewide network
- ◆ Serving community of Redwood Falls since 2002

5/11/2023

© 2023 Nuvera. All rights reserved.

4

Building Nuvera Gig Communities: Continual investment is in our DNA



- For more than a decade and through 2021, we have been extending our fiber network into communities
- In 2022 we began accelerating our fiber expansion process to extend access to fiber-based Internet service delivering Gig speeds
- Total project investment \$250M +
- Nuvera Gig Cities project will take a few years start to finish
- Gig cities:
 - New Ulm, Hutchinson, Glencoe, Goodhue, Litchfield, Redwood Falls, Prior Lake, Elko New Market, Savage, Sleepy Eye, Springfield, and more surrounding areas.
- Fiber Build Investment in Redwood Falls: 5 Million

5/11/2023

© 2023 Nuvera. All rights reserved.

5

5

Fiber is the gold standard for making connections



- ◆ Speed
 - Moving at the speed of light
 - Up to 1 Gig symmetrical speeds
 - Scalable for future needs
- ◆ Reliability
 - Seamless connection to minimize buffering for a better streaming experience
- ◆ Future proof
 - Unlimited capacity to support emerging technologies
 - Video (4K and 8K)
 - IoT and smart home devices
 - Artificial Intelligence (AI)



5/11/2023

© 2023 Nuvera. All rights reserved.

6

6

Pricing is the same for all communities regardless of geography



NuFiber
99.99 /MTH
UP TO
1 GIG
Plus taxes and equipment fees. Home WiFi Premium included.

NuFiber
74.99 /MTH
UP TO
500 Mbps
Plus taxes and equipment fees. Home WiFi Premium included.

NuFiber
49.99 /MTH
UP TO
100 Mbps
Plus taxes and equipment fees.

Residential pricing

- ◆ Additional \$6.95 monthly modem fee applies
- ◆ Wi-Fi router included with most fiber plans (200, 500, Gig) and includes parental control options
 - Home WiFi: \$6.95/mo
 - Home WiFi Premium: \$12.95/mo
- ◆ Standard broadband pricing for ALL geographies (no rural pricing discrimination)
- ◆ Federal Broadband programs available for qualified households
- ◆ Drop (curb to home) built to current customers at no charge
- ◆ Non-customers must subscribe to service before a drop is buried to home

5/11/2023

© 2023 Nuvera. All rights reserved.

7

7

Your Community thrives with strong connections



- ◆ Economic development opportunities attract high value jobs
- ◆ Competitive advantage to attract and retain Gig workers/learners as residents
- ◆ Fiber home values increase by an average of 3.1%*
- ◆ Local teams mean fast, convenient installations and repairs



*National study conducted by UC Boulder and Carnegie Mellon

5/11/2023

© 2023 Nuvera. All rights reserved.

8

8

Construction Plan & Build Process



- 2 Year build plan
- Year 1 construction planned to begin June 1st and end December 2023
- 2023 build will be generally south of Highway 19
- 2023 build area will be divided into 5 Nodes. As areas are completed, we will schedule customer installations
- Building drops to non-customer households committing to service
- Existing customers must transition to new fiber network

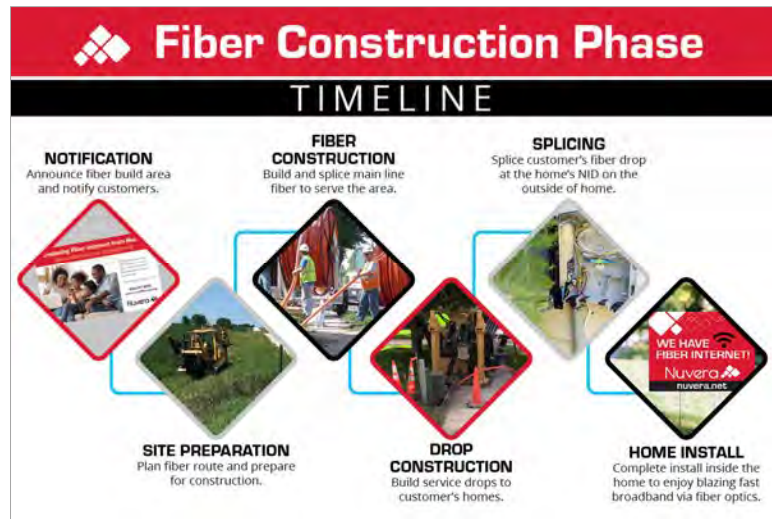

5/11/2023

© 2023 Nuvera. All rights reserved.

9

9

Construction Process Detail



5/11/2023

© 2023 Nuvera. All rights reserved.

10

10

2023 Fiber Build Area

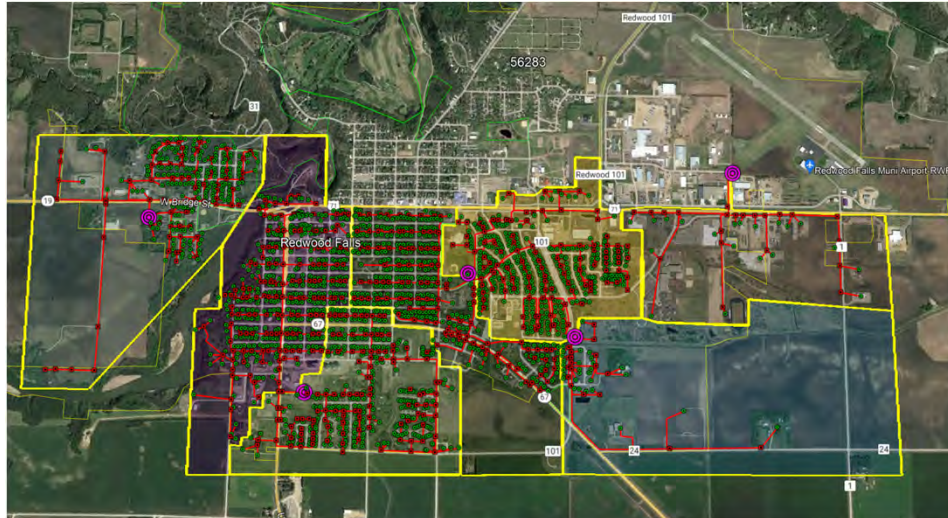

5/11/2023

© 2023 Nuvera. All rights reserved.

11

11

Collaboration is key to our mutual success



- ◆ Upcoming construction projects
 - Joint projects will be efficient and less disruptive to community
- ◆ Streamline the permitting process and facility locates
- ◆ Facilitate multiple Nuvera construction crews for project efficiency
- ◆ Help communicate construction updates on city website and social media accounts
- ◆ Participate/support opportunities for project exposure



5/11/2023

© 2023 Nuvera. All rights reserved.

12

12



Thank you!

13

Nuvera 

14



Jim Doering
Public Works Project Coordinator
Phone: 507-616-7400
Fax: 507-637-2417
jdoering@ci.redwood-falls.mn.us

Meeting Date: May 16, 2023

AGENDA RECOMMENDATION

Agenda Item: Approval of Plans and Authorization to Bid

Recommendation/Action Requested: Staff recommends approving the plans and specs, and authorizing advertisement for bids, for the 2023 Fourth Street Improvement Project.

Summary/Overview: Attached to this cover is a signature plan sheet for the 2023 Fourth Street Improvement Project. The total Engineer's Estimate for construction is \$4.99 million with contingency.

Per Council approved Task Order 2023-1 on January 3, 2023, Bolton & Menk Inc. (BMI) have put together the advertisement for bids, bid specifications, and plan set for the 2023 Fourth Street Improvement Project per the scope of the Task Order 2023-1. BMI and Staff are waiting for final federal authorization to bid due to the federal grant component. Staff are recommending approval to expedite the bid process.

Upon Federal authorization, the earliest contract award would be at the June 20th Council meeting with a July 1 start date.

The project by utility is included in the proposed 2023 budget with a project estimate of \$4,990,566.00. Expected Revenues of \$1,540,910.00 up to \$1,968,296.00 in Federal STIP funding and up to \$1,156,374.00 in State MSAS funding with a local utility match of \$1,865,896.00. The estimated project expenses consist of the anticipated construction costs, contingency, engineering, and legal/administrative costs.

The bid set, plans, and specifications are a 40MB document and was not included with this agenda item. Access to a full set is available upon request.

Attachments: Plan Cover Sheet

DESIGN DESIGNATION MSAS 119
 STA. 0+72.40 TO STA. 29+76.00

FUNCTIONAL CLASSIFICATION MINOR COLLECTOR
 R-VALUE 8 (ASSUMED)
 SN-18 99,000
 NO. & WIDTH OF TRAFFIC LANES 2 & 11 ft, 11.33 ft, 12 ft
 NO. & WIDTH OF PARKING LANES 2 & 7 ft and 10 ft
 ADT (PRESENT YEAR) 2023 700
 ADT (PROJECTED YEAR) 2043 1,050
 HCADT (PROJECTED YEAR) 2043 3.86%
 DESIGN SPEED 30 mph
 DESIGN LOAD 10 ton
 DESIGN SPEED NOT ACHIEVED AT:
N/A

DESIGN SPEED FOR ROADWAY BASED ON
 ON STOPPING SIGHT DISTANCE:
 HEIGHT OF EYE = 3.5 FT
 HEIGHT OF OBJECT = 2.0 FT

MINNESOTA DEPARTMENT OF TRANSPORTATION

CITY OF REDWOOD FALLS

REDWOOD COUNTY, MINNESOTA

MUNICIPAL STATE AID STREET 119 (4TH STREET)

CONSTRUCTION PLAN FOR: GRADING, AGGREGATE BASE, PLANT MIXED BITUMINOUS PAVEMENT, CONCRETE CURB AND GUTTER, CONCRETE SIDEWALK, ADA IMPROVEMENTS, STORM SEWER, SANITARY SEWER, WATER MAIN, LANDSCAPING AND RELATED APPURTENANCES

SP 207-119-001 LOCATED ON MSAS 119 FROM TRUNK HIGHWAY 71 (MILL STREET) TO GOULD STREET (GEOGRAPHICAL DESCRIPTION)
 FROM 700' EAST OF SECTION 1, T112N, R36W TO THE EAST LINE OF SECTION 1, T112N, R36W (LEGAL DESCRIPTION)

MSAS 119 (SP 207-119-001)

GROSS LENGTH	<u>2903.60</u>	FEET	<u>0.550</u>	MILES
BRIDGE LENGTH	<u>N/A</u>	FEET	<u>N/A</u>	MILES
EXCEPTION LENGTH	<u>0.00</u>	FEET	<u>0.000</u>	MILES
NET LENGTH	<u>2903.60</u>	FEET	<u>0.550</u>	MILES

LENGTH AND DESCRIPTION BASED UPON
 PROPOSED MSAS 119 CENTERLINE

END PROJECT: SP 207-119-001 (MSAS 119)
 REF. PT 0+00.564 STA. 29+76.00

BEGIN PROJECT: SP 207-119-001 (MSAS 119)
 REF. PT 0+00.014 STA. 0+72.40

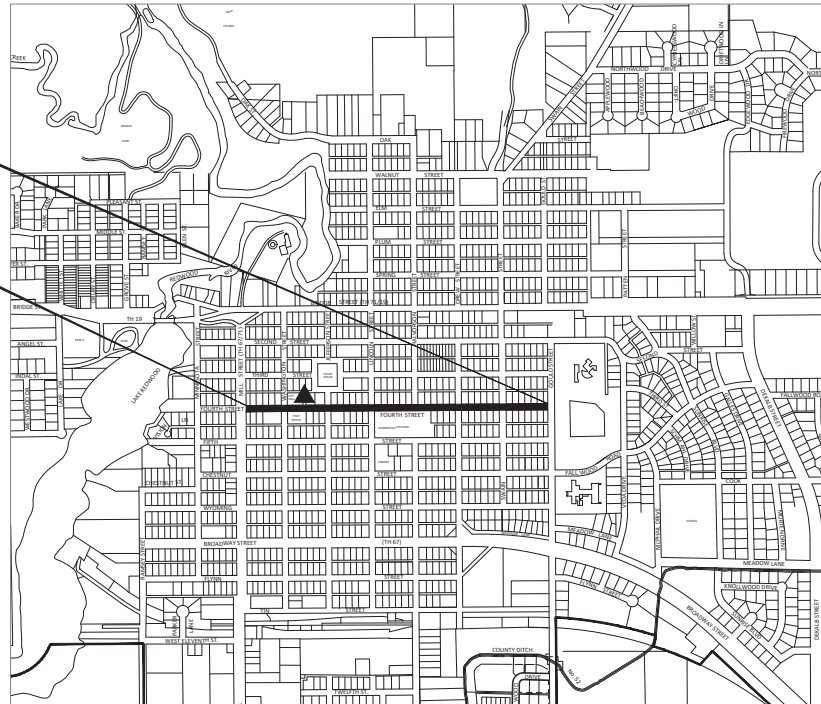

TYPICAL PLAN SCALE
 UNLESS OTHERWISE NOTED:

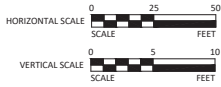

PROJECT LOCATION



CITY: REDWOOD FALLS
 COUNTY: REDWOOD
 DISTRICT: 8

VICINITY MAP

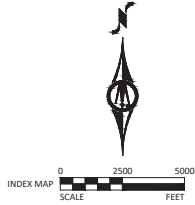

MAP LEGEND

- ▬ PROJECT LIMITS
- ▲ BID LOCATION

BM=996.967
 MNDOT GSD #104132
 AT THE JUNCTION OF TH 19 AND
 TH 67 AND TH 71

PROJECT DATUM: REDWOOD COUNTY COORDINATES
 HORIZONTAL: NAD83 (2011)
 VERTICAL: NAVD88

RECORD DRAWING INFORMATION	
DESIGNER:	
DRAWN:	
CHECKED:	
DATE:	

MINN. PROJ. NO. _____

--- GOVERNING SPECIFICATIONS ---
 THE 2020 EDITION OF THE MINNESOTA DEPARTMENT OF TRANSPORTATION
 "STANDARD SPECIFICATION FOR CONSTRUCTION" AND THE "SUPPLEMENTAL
 SPECIFICATIONS" DATED SEPTEMBER 2022 SHALL GOVERN.

ALL TRAFFIC CONTROL DEVICES AND SIGNING SHALL CONFORM AND BE INSTALLED IN
 ACCORDANCE WITH THE LATEST "MINNESOTA MANUAL ON UNIFORM TRAFFIC CONTROL DEVICES"
 (MN MUTCD) AND PART VI, THE LATEST "FIELD MANUAL" FOR TEMPORARY TRAFFIC CONTROL
 DEVICES.

SHEET NUMBER	SHEET TITLE
GENERAL	
1	TITLE SHEET
2	LEGEND
3 - 4	STATEMENT OF ESTIMATED QUANTITIES
5 - 9	TABULATIONS
CIVIL	
10 - 11	REMOVAL PLAN
12 - 27	TYPICAL SECTIONS, DETAILS, & STANDARD PLANS
28 - 34	STORMWATER POLLUTION PREVENTION PLAN
35 - 42	UTILITY PLAN & PROFILE
43 - 47	STREET PLAN & PROFILE
48 - 52	INTERSECTION DETAILS
53 - 55	TRAFFIC CONTROL PLAN
56 - 60	SIGNAGE & STRIPING PLAN
61 - 67	CROSS SECTIONS

THIS PLAN SET CONTAINS 67 SHEETS.

Owens J. Todd

OWEN J. TODD, P.E.
 I HEREBY CERTIFY THAT THIS PLAN, SPECIFICATION, OR REPORT WAS PREPARED BY ME OR UNDER MY DIRECT
 SUPERVISION AND THAT I AM A DULY LICENSED PROFESSIONAL ENGINEER UNDER THE LAWS OF THE STATE OF
 MINNESOTA.

DATE 02/24/2023 LICENSE NUMBER 24751

APPROVED *Owens J. Todd* Date 02/24/2023
 CITY OF REDWOOD FALLS ENGINEER

DISTRICT STATE AID ENGINEER
 REVIEWED FOR COMPLIANCE WITH STATE AID AND/OR FEDERAL AID RULES/POLICY

STATE AID ENGINEER
 APPROVED FOR STATE AID AND/OR FEDERAL AID FUNDING

CITY OF REDWOOD FALLS, MINNESOTA
 4TH STREET IMPROVEMENTS (SP 207 - 119 - 001)

STATE PROJECT NO. 207-119-001

SHEET
1
 OF
67



1243 CEDAR STREET NE
 SLEEPY EYE, MINNESOTA 56085
 Phone: (507) 794-5541
 Email: SleepyEye@bolton-menk.com
 www.bolton-menk.com

DESIGNED:	STT
DRAWN:	STT, BMH
CHECKED:	
DATE:	
CLEARING NO.:	514.116997



Trenton Dammann
City Attorney
Phone: (507)616-7400
Fax: (507)637-2417

tdammann@ci.redwood-falls.mn.us

AGENDA MEMO

Meeting Date: May 16, 2023

Agenda Item: Approval of Resolution No. 28 of 2023 – Authorization to Execute Contract for Conflict Prosecution Services with Redwood County

Recommendation/Action Requested: Discuss the proposed agreement. If there are no concerns, staff recommend approval of the proposed agreement by motion in accordance with Chapter 4 of the City Charter.

Summary/Overview: Minn. Stat. Sec. 484.87, subd. 3 requires that the prosecution of certain petty misdemeanor, misdemeanor, and gross misdemeanor violations of state law be handled by the Redwood Falls City Attorney.

Under certain circumstances, such as the prosecution of an alleged offense involving city employees, Council Members, or when conflicts of interest may exist that would preclude prosecution of an alleged offense by the City Attorney, the City may need to involve an outside prosecutor to provide prosecution services on behalf of the City. Staff have determined that it is best practice to have a Conflict Prosecution Attorney retained by agreement prior to the need for such services to dispel any notion of bias when selecting another attorney to perform the functions of the City Attorney as a criminal prosecutor.

Redwood County, through the Redwood County Attorney's Office, is willing to provide Conflict Prosecution Services as the Conflict Prosecution Attorney on an as-needed basis to the City. The Agreement memorializes the scope of work, fee arrangements, duties and responsibilities of both parties during the term of the Agreement.

Attachments: Resolution No. 28 of 2023

Contract for Conflict Prosecution Services Between City of Redwood Falls and Redwood County

RESOLUTION NO. 28 OF 2023

AUTHORIZATION TO EXECUTE CONTRACT FOR CONFLICT PROSECUTION SERVICES WITH REDWOOD COUNTY

WHEREAS, the City of Redwood Falls (hereinafter the “City”) desires to enter into a “Contract for Conflict Prosecution Services Between City of Redwood Falls and Redwood County,” hereinafter, the “Agreement,” with Redwood County (hereinafter the “County”), pursuant to Minnesota Statutes Section 412.221, subd. 2 for the benefit of its citizens; and

WHEREAS, Minn. Stat. Sec. 484.87, subd. 3 requires that the prosecution of certain petty misdemeanor, misdemeanor, and gross misdemeanor violations of state law be handled by the Redwood Falls City Attorney (“City Attorney”); and

WHEREAS, under certain circumstances, such as the prosecution of an alleged offense involving city employees, council members, or when conflicts of interest may exist that would preclude prosecution of an alleged offense by the City Attorney, the City may need to involve an outside prosecutor to provide prosecution services on behalf of the City (“Conflict Prosecution Attorney”); and

WHEREAS, County, through the Redwood County Attorney’s Office as the Conflict Prosecution Attorney, is willing to provide Conflict Prosecution Services on an as-needed basis to the City; and

WHEREAS, City and County desire to memorialize their agreement on the scope of work and fee arrangements; and

WHEREAS, the Agreement outlines the duties and responsibilities of both the City and County during the term of the Agreement including records management, defines certain words, outlines the services to be provided, and provides for fees, charges, and billing.

NOW, THEREFORE, BE IT RESOLVED BY THE CITY COUNCIL OF REDWOOD FALLS, MINNESOTA, AS FOLLOWS:

1. The Agreement described above is approved in the form submitted to the City Council and made a part of this Resolution by reference.
2. The Agreement described above shall be maintained and insured by the City as allowed by law.

PASSED AND ADOPTED by the City Council of the City of Redwood Falls, Minnesota this 16th day of May, 2023.

ATTEST:

Keith Muetzel, City Administrator

Tom Quackenbush, Mayor

(City Seal)

Subscribed and sworn to before me this
16th day of May, 2023.

Notary Public

**CONTRACT FOR CONFLICT PROSECUTION SERVICES
BETWEEN CITY OF REDWOOD FALLS
AND REDWOOD COUNTY**

WHEREAS, This Conflict Prosecution Services contract (“Agreement”) is made by and between the City of Redwood Falls (“City”), a Minnesota municipal corporation, and the County of Redwood (“County”), a political subdivision of the State of Minnesota.

RECITALS

- A. Minn. Stat. Sec. 484.87, subd. 3 requires that the prosecution of certain petty misdemeanor, misdemeanor, and gross misdemeanor violations of state law be handled by the Redwood Falls City Attorney (“City Attorney”).
- B. Under certain circumstances, such as the prosecution of an alleged offense involving city employees, council members, or when conflicts of interest may exist that would preclude prosecution of an alleged offense by the City Attorney, the City may need to involve an outside prosecutor to provide prosecution services on behalf of the City (“Conflict Prosecution Attorney”).
- C. County, through the Redwood County Attorney’s Office as the Conflict Prosecution Attorney, is willing to provide Conflict Prosecution Services on an as-needed basis to the City.
- D. City and County desire to memorialize their agreement on the scope of work and fee arrangements.

I. DEFINITIONS

- A. **Criminal Prosecution** shall mean providing legal representation on behalf of the City for the enforcement of laws of the State of Minnesota or the ordinances of the City using the criminal justice system. Criminal Prosecution specifically involves the prosecution of all city ordinance violations, petty misdemeanors, all misdemeanors, and any gross misdemeanor violations of Minn. Stat. Sections 169A, 171, and 169 occurring within the City or where State statutes otherwise confer prosecutorial jurisdiction over the offense on the prosecuting authority for the City.
- B. **Conflict Prosecution Services** shall mean providing legal representation on behalf of the City for Criminal Prosecution when the City Attorney, in its discretion, determines a conflict of interest exists in a specific circumstance that warrants a Conflict Prosecution Attorney. Conflict Prosecution Services shall include all prosecution services to victims of crime as provided in Minnesota Statute Chapter 611A.

II. SERVICES PROVIDED

County shall provide Conflict Prosecution Services during the term of this Agreement.

III. FILES AND RECORDS

File Maintenance. County will keep complete files and records for all matters handled for the City in accordance with County’s approved Data Retention Schedule. All files and records may be created, maintained, and stored electronically. An updated index of such files will be provided to the City upon request. Files no longer needed for current matters may be commercially archived, and any cost of said archiving shall be a charge, which may be billed in addition to the fees set forth in Section IV. If the City desires any or all of its files, County shall incur the copy cost on any file copies that County desires to copy and retain.

Pursuant to Minnesota Statutes § 16C.05, Subd. 5, as applicable, County agrees that the books, records, documents, and accounting procedures and practices of County, that are relevant to the Agreement or transaction, are subject to examination by the City and either the legislative auditor or the state auditor, as appropriate, for a minimum of six years. County shall maintain such records for a minimum of six years after payment of the last invoice sent upon resolution of each criminal matter.

Data Practices Act. Pursuant to the provisions of Minn. Stat. § 13.05 subd. 11, all data created, collected, received, stored, used, maintained, or disseminated by County in performing Conflict Prosecution Services on behalf of the City is subject to the requirements of Minnesota Statutes Chapter 13, and County shall comply with the requirements of Minnesota Statutes Chapter 13. All data supplied to County shall be administered consistent with the provisions of Minnesota Statutes Chapter 13 and data on individuals shall be maintained according to the statutory provisions applicable to the data.

File Destruction. County may destroy files and records pertaining to a concluded matter in accordance with County’s approved Data Retention Schedule.

IV. FEES, CHARGES AND BILLING

County will bill the City monthly for the following fees and charges for Conflict Prosecution Services provided to the City as follows:

<u>Scope of Services</u>	<u>Fees</u>
All Inclusive Billing Rate	\$175/hour
All time will be billed in minimum increments of one-fourth (.25) hour.	

V. INDEPENDENT CONTRACTOR

The parties intend that an independent contractor relationship will be created by this Agreement. The City is interested only in the results to be achieved, and the conduct and control of the work will lie solely with the County. County is not to be considered an agent or employee of the City for any purpose. No tenure or any rights or benefits, including workers compensation, unemployment insurance, medical care, sick leave, vacation leave, severance pay, PERA, or other benefits available to City employees, shall accrue to the County.

V. INSURANCE

County agrees under the indemnity provisions set forth below, the County will at all times during the term of this Agreement keep appropriate insurance in force.

VI. HOLD HARMLESS AND INDEMNIFY

County agrees that it will defend, indemnify and hold harmless the City, its elected officials, officers, employees, and volunteers against any and all liability, loss, costs, damages, and expenses which the City, its elected officials, officers, employees, or volunteers may hereafter sustain, incur or be required to pay arising out of the County's negligent performance or failure to adequately perform their obligations pursuant to this Agreement.

VII. TERM

This Agreement shall be effective as of May 16, 2023, and shall continue until such time as it is terminated by either party. Either party may terminate this Agreement by providing sixty (60) days' written notice to the other party.

VIII. ENTIRE AGREEMENT

This Agreement constitutes the entire agreement between the parties, and any prior understanding or representation of any kind preceding the date of this Agreement shall not be binding on either party except to the extent incorporated in this Agreement.

IX. MODIFICATION OF AGREEMENT

Any modification of this Agreement or additional obligation assumed by either party in connection with this Agreement shall be binding only if in writing signed by each party or an authorized representative of each party.

X. GOVERNING LAW

This Agreement shall be governed by, construed, and enforced in accordance with the laws of Minnesota.

XI. CONFLICT OF INTEREST

Conflict Prosecution Attorney affirms that, to the best of the Conflict Prosecution Attorney's knowledge, the Conflict Prosecution Attorney's involvement in this Agreement does not result in a

conflict of interest with any party or entity, which may be affected by the terms of this Agreement. Should any conflict or potential conflict of interest, as identified by Conflict Prosecution Attorney, become known to Conflict Prosecution Attorney, it will immediately notify the City Attorney of the conflict or potential conflict and will advise the City Attorney whether the Conflict Prosecution Attorney will or will not resign from Conflict Prosecution Services. Should the Conflict Prosecution Attorney resign from Conflict Prosecution Services, the matter shall be returned to the City Attorney.

This Agreement is executed by the following authorized representatives of the parties hereto:

City of Redwood Falls, Minnesota,
a Minnesota Municipal Corporation.

By: _____
Tom Quackenbush, Mayor

By: _____
Keith Muetzel, City Administrator

STATE OF MINNESOTA)
) ss.
COUNTY OF REDWOOD)

The foregoing instrument was acknowledged before me on this ____ day of _____, 2023, by Tom Quackenbush and Keith Muetzel, Mayor and City Administrator respectively, of the City of Redwood Falls, a Minnesota Municipal Corporation, on behalf of the City.

Notary Public

Redwood County
a political subdivision of the State of Minnesota.

By: _____

STATE OF MINNESOTA)
) ss.
COUNTY OF REDWOOD)

The foregoing instrument was acknowledged before me on this ____ day of _____, 2023, by _____, who is the _____ of Redwood County, a

political subdivision of the State of Minnesota.

Notary Public

Redwood County
a political subdivision of the State of Minnesota.

By: _____

STATE OF MINNESOTA)
) ss.
COUNTY OF REDWOOD)

The foregoing instrument was acknowledged before me on this ____ day of _____, 2023, by _____, who is the _____ of Redwood County, a political subdivision of the State of Minnesota.

Notary Public



Keith Muetzel
City Administrator
Phone: 507-616-7400
Fax: 507-637-2417

kmuettel@ci.redwood-falls.mn.us

Meeting Date: May 16, 2023

AGENDA RECOMMENDATION

Agenda Item: Establish City Council Work Session Agenda

Recommendation/Action Requested: Staff requests the City Council formally establish the agenda for the May 30, 2023, work session.

Summary/Overview: The next City Council work session is scheduled for May 30, 2023. In order to prepare for the meeting, and ensure adequate time is allowed for each agenda item, staff is requesting the City Council formally establish the work session agenda.

Attachments: None